

GW-7228 J1939 to Modbus RTU Gateway Quick Start Guide

Product Website

http://www.icpdas-usa.com/gw_7228.html

Package checklist

The package includes the following items:

- GW-7228 module
- Quick Start Guide
- Software utility
- CD Screw driver
- RS-232 cable (CA-0910)



Appearance and pin assignments

CAN DB9 Male Connector

Pin	Description
1	Not Connect
2	CAN Low
3	CAN Ground
4	Not Connect
5	
6	CAN Ground
7	CAN High
8	Not Connect
9	

14-pin screw terminal connector

Pin	Description
1	RS-485 DATA+
2	RS-485 DATA-
3	Not Connect
4	RS-422 Tx+
5	RS-422 Tx-
6	RS-422 Rx+
7	RS-422 Rx-
8	Not Connect
9	RS-232 RXD
10	RS-232 TXD
11	RS-232 GND
12	Not Connect
13	+Vs(+10 ~ +30 VDC)
14	GND



Figure 1: Appearance of the GW-7228

LED Indication

LED indication of the GW-7228

LED Name	GW-7228 Status	LED Status
ALL LEDs	Firmware Updating Mode	All LED always turned on
	Hardware WDT Fail	All LED blink per 1 second
	Contact to ICP DAS	All LED blink per 100 ms
PWR LED	No Error	Always turned on
	CAN Bus Transmission Fail	Blink per 100 ms
	CAN Bus-Off	Blink per 500 ms
	Can't Claim Address in J1939 Network	Blink per 1000 ms
	Power Failure	Off
J1939 LED	Transmission	Blink
	Bus Idle	Off
MODBUS LED	Transmission	Blink
	Bus Idle	Off

Installation

If users want to start the GW-7228 normally, it needs to follow these steps to install the GW-7228 below:

Step1: Check GW-7228 Firmware Mode

Users need to set the dip-switch to the “Normal” position as Figure 2 and reset the power, and then the GW-7228 would run in the operation mode.

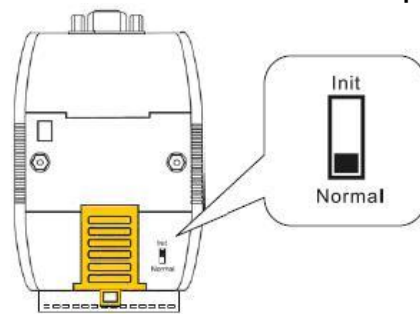

Figure 2: Operation mode Position of Dip-Switch

Step2: J1939 network - CAN bus connection

Connect the CAN ports with the GW-7228 modules and ECU (e.g. engine) in J1939 network using the following structure as Figure 3.

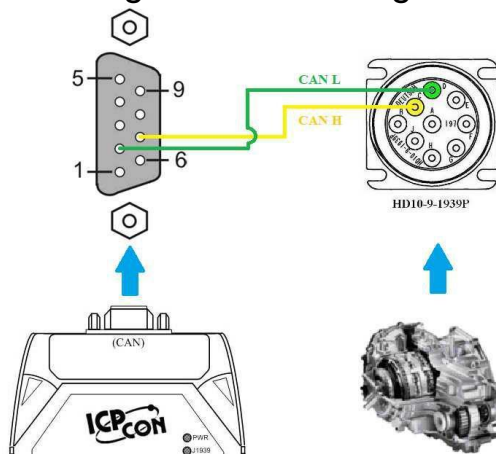

Figure 3: CAN bus Wire Connection

Step3: Modbus network - Serial port connection

It is recommended to use only one serial port (RS232, RS422 or RS485) of the gateway at the same time. The following figure describes the three COM port types to a serial device via serial network.

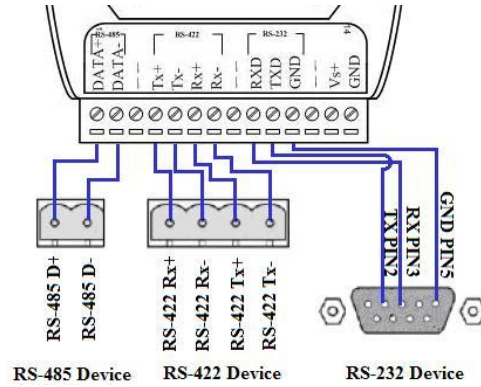

Figure 4: Serial port wire connection

Step4: Power wire connection

Connect the power supply to the GW-7228 module's power terminal connector, please see the following connection as Figure 5.

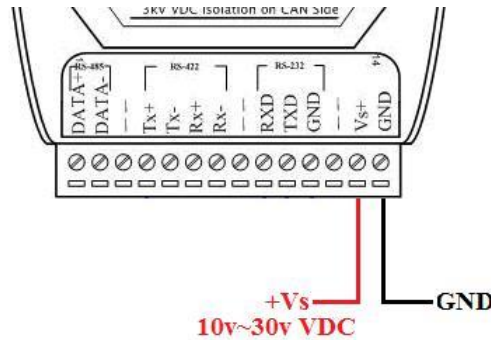

Figure 5: Power Wire Connection

GW-7228 Utility Configuration

Modbus Network Configuration

The GW-7228 and the controller must be set the same serial communication parameters of the Modbus network configuration. The Modbus network configuration screen from GW-7228 is shown as Figure 6.



Figure 6: Modbus configuration screen

J1939 Network Configuration

The device NAME should be set according to the application and the vendor where the module is being used based on the J1939 network specification.

The J1939 network configuration screen from the GW-7228 is shown as Figure 7.

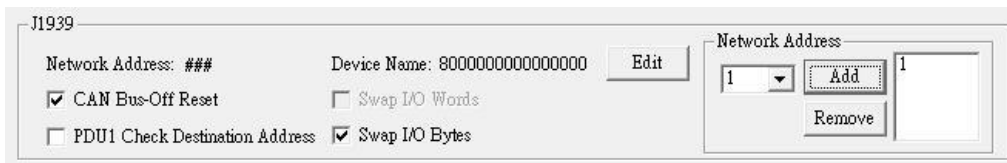

Figure 7: Modbus configuration screen

J1939 I/O Configuration

The following figure is a PGN definition about Electronic Transmission Controller, we want to receive the Transmission Output Shaft Speed from the transmission and send the Transmission Input Shaft Speed to the transmission via the GW-7228. The following table shows the current planning.

PGN	61442	Electronic Transmission Controller 1	- ETC1
Transmission Repetition	10 ms		
Data Length:	8		
Data Page:	0		
PDU Format:	240		
PDU Specific:	2	PGN Supporting Information:	
Default Priority:	3		
Parameter Group Number:	61442	(0xF002)	
Start Position	Length	Parameter Name	SPN
1.1	2 bits	Transmission Driveline Engaged	560
1.3	2 bits	Torque Converter Lockup Engaged	573
1.5	2 bits	Transmission Shift In Process	574
2-3	2 bytes	Transmission Output Shaft Speed	191
4	1 byte	Percent Clutch Slip	522
5.1	2 bits	Engine Momentary Overspeed Enable	606
5.3	2 bits	Progressive Shift Disable	607
6-7	2 bytes	Transmission Input Shaft Speed	161
8	1 byte	Source Address of Controlling Device for Transmission Control	1482

Figure 8: Example of a parameter group definition of SAE J1939/71

Table 1: Configuration data of J1939 and Modbus

Parameters	PGN	Data Length (bytes)	Byte Order In J1939 Data Field	Byte Order in MODBUS	MODBUS Address
Send					
Input Shaft Speed	61442(Dec) F002(Hex)	2	5	0	40001
Receive					
Output Shaft Speed	61442(Dec) F002(Hex)	2	1	0	30001

Note:PGN/Data Length(Bytes)/Byte Oder in J1939 Data Field

=> Transmission manufacturers provide the information required

Byte Order in MODBUS

=> User-defined Modbus address

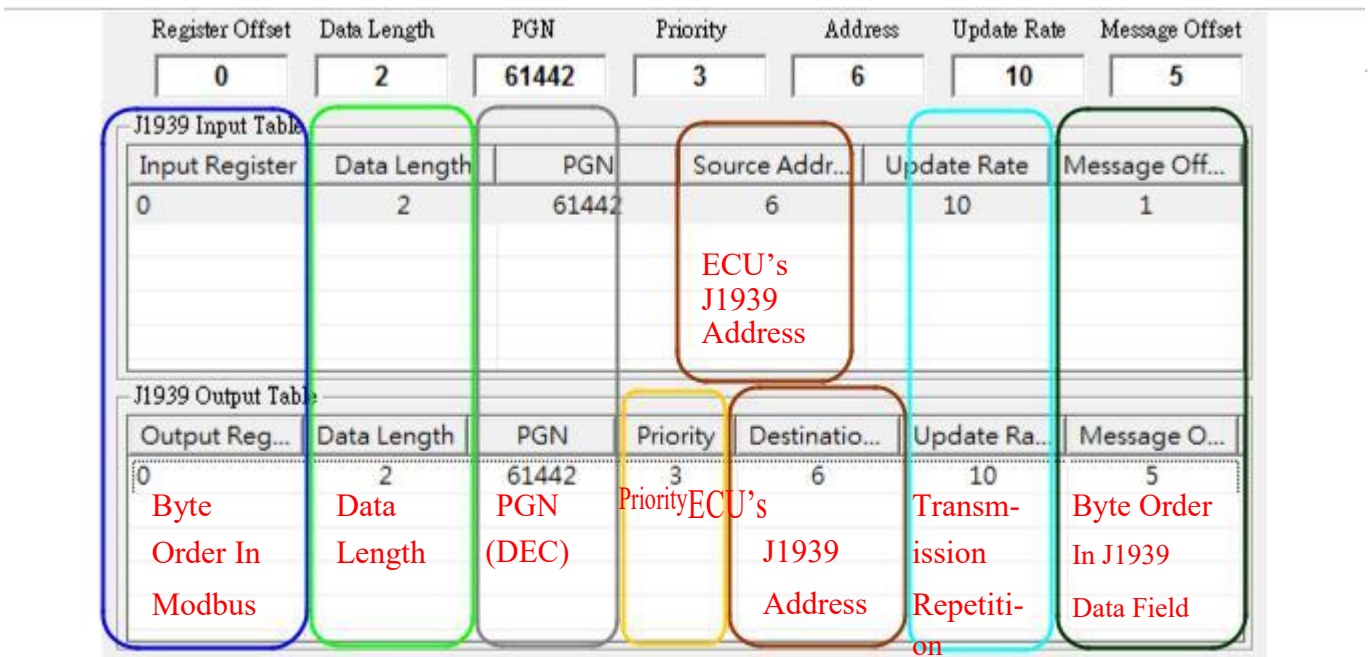

Figure 9: J1939 configuration screen

Upload Parameter to the GW-7228

After the previous parameter settings, users need to upload the parameters to the GW-7228.



Figure 10: Parameter upload screen

Modbus Communication

Set J1939 output data

Using the Modbus command as below:

FC16 Write multiple registers (4xxxx) for AO

Example:

In the address 40001, write the value in 0x1234.

[Request Command] (Byte0, Byte1... Byten) (Hex) 01
10 00 00 00 01 02 **12 34** AB 27(CRC)

Get J1939 input data

Using the Modbus command as below:

FC4 Read multiple input registers (3xxxx) for AI

Example:

Read a value of one word in the address 30001.

[Request] (Byte0, Byte1... Byten) (Hex) 01
04 00 00 00 01 31 CA(CRC)

GW-7228 responds a value of one word in the address 30001.

[Response](Byte0, Byte1... Byten) (Hex) 01
04 02 **12 34** B4 47(CRC)

Start or Stop sending J1939 output message

1、 Using the Modbus command as below:

FC6 Write single register (4xxxx) for AO

Example: Start sending J1939 output message In the address 42009, write the value in 0x00.

[Request Command] (Byte0, Byte1... Byten) (Hex) 01
06 07 D8 00 00 08 85(CRC)

Example: Stop sending J1939 output message In the address 42009, write the value in 0x01.

[Request Command] (Byte0, Byte1... Byten) (Hex) 01
06 07 D8 00 01 C9 45(CRC)

Or

2、 Enable / Disable the Auto Transmission function as below, and upload to GW-7228:

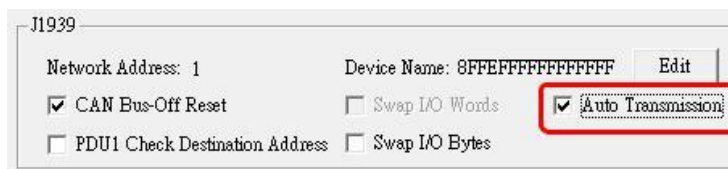
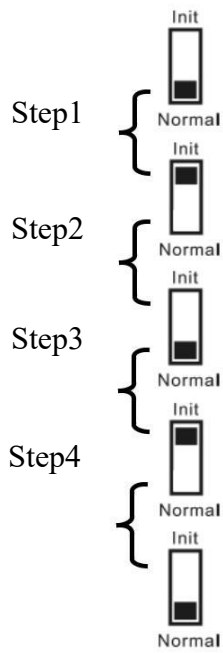

Figure 11: J1939 Auto Transmission function screen

Troubleshooting

Item	Trouble state	Solution
1	CAN Bus Transmission Fail (Power LED Blink per 100 ms)	Make sure the CAN bus wiring is connected, and connected to the correct pin.
2	CAN Bus-Off (Power LED Blink per 500 ms)	Make sure the CAN bus wiring does not short-circuit
3	Can not Claim Address in J1939 Network (Power LED Blink per 1000 ms)	Please configure another J1939 network address in GW-7228 Utility.
4	Can not transmit the output J1939 message	<ol style="list-style-type: none"> 1. Make sure the Start/Stop sending J1939 output message register (42009) is 0x00. 2. Make sure the Update Rate of J1939 output message table is not zero.
5	<p>How to restore factory default</p> 	<ol style="list-style-type: none"> 1. Power on the GW-7228 2. Change the Dip-Switch position of the GW-7228 and to complete the following steps in 5 seconds. <ul style="list-style-type: none"> Step1. From “Normal” to “Init” position. Step2. From “Init” to “Normal” position. Step3. From “Normal” to “Init” position. Step4. From “Init” to “Normal” position. 3. When the correct implementation of the above steps, the J1939/Modbus LEDs of the GW-7228 should be turn on, and that should be turn off after 500 ms later. 4. Reset the power of the GW-7228, and the GW-7228 would back to factory defaults. 5. Reconnect the GW-7228 by using the network setting as 115200 baud with none parity, 1 stop bit and 1 Net ID.